

Roof fan

DTH20041EC DTH20041EC

Roof fan with horizontal exhaust and openable housing. DTH is made from cast aluminium, giving it high corrosion resistance. Can be mounted on roof cowl TGK/TGR



PRODUCT BENEFITS

- High corrosion resistance
- Backward curved blades
- High efficiency
- Low operating costs
- Can be mounted on roof cowl TGK/TGR

Product description

DESCRIPTION:

The DTH roof fan is an extraction ventilator manufactured in cast aluminium, ensuring long-term, problem-free operation. TGK/TGR roof cowls are available for this, ensuring simple and correct ventilation.

The DTH roof fan has a backward-curved B impeller in aluminium with a horizontal air exhaust and can be opened for cleaning. DTH is available in 5 sizes: DTH160, -200, -250, -315 and -400.

MOTORS:

DTH160 and -200 have a single-phase motor, while the other models have an EC motor.

TEMPERATURE:

In normal operation, DTH tolerates temperatures up to 60 °C.

Combustion-gas fan

If a certified fire gas fan is required, we refer to SEF roof fan.

Accessories

Description	Variants
MAC12 constant pressure regulator	MAC12
HW050X08002U0UL	SWDTH
EFC1P2, Electronical speed regulator	EFC1P2

Fan data

Max. Total efficiency (A-D) (%)	38,5
Ventilation energy class - Average climate	C
Efficiency level requirements	62, N(2015)
ECO efficiency level during optimal operating point	70,7
Nominal speed (RPM)	1400
Power supply	1x230 V - 50Hz
Overload protection	Integral thermal cutout (TP211) in motor power circuit
Engine power (kW)	0,04

Roof fan

DTH20041EC
DTH20041EC

Dimensional data

A (mm)	225
B (mm)	365
C (mm)	260
D (mm)	70
E Ø (mm)	200
Weight (kg)	13

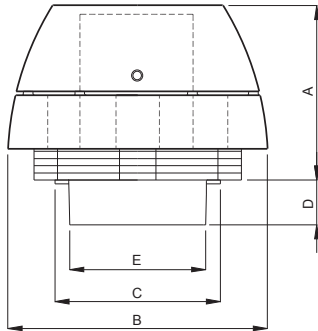

Installation

DTH fans are designed for use with TGR or TGK roof vents, for simple and optimal installation.

DTH is simply lowered over the roof vent, and its weight holds it in place. Vibration-damping materials are also supplied to ensure that vibrations from DTH are not transferred to the duct system.

TGR and TGK roof vents are insulated for sound and condensation and have an integral cable penetration. As an accessory an AOR anti-back-draught shutter and bracket can be selected.

Airflow data

Minimum airflow	120
Max. airflow (m ³ /h)	800

Electrical datas

Voltage (V)	1x230
Frequency (Hz)	50
Max. current (A)	0,35
Engine power (kW)	0,04

Regulatory data

Ventilation energy class - Average climate	C
--	---

Installation



DESIGN

The DTH is made of cast aluminium, which gives it a high corrosion resistance (Corrosion class C4 according to EN ISO 12944-2).

It is painted in black RAL 7021, a suitable colour for most roofs.

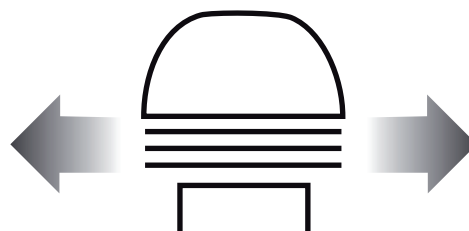

HORIZONTAL EXHAUST

DTH is an extract fan with a horizontal exhaust.

The design ensures an optimum air handling solution with minimum noise.



FAN IMPELLER

DTH roof fan is ideal for ventilation tasks requiring efficient and economical ventilation.

The specially developed centrifugal impeller with backward curved blades ensures high efficiency and low operating costs.

Roof fan

DTH20041EC
DTH20041EC



SERVICE
DTH roof fan is easy to open for cleaning and maintenance.

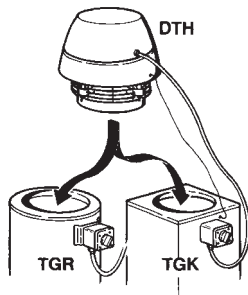

DTH fans are designed for use with TGR or TGK roof cowl, for simple and optimal installation.

DTH is simply lowered over the roof cowl, and its weight holds it in place. Vibration-damping materials are also supplied to ensure that vibrations from DTH are not transferred to the duct system.

TGR and TGK roof cowl are insulated for sound and condensation and have an integral cable penetration. As an accessory an AOR anti-backdraught shutter and bracket can be selected.

Curve

