

CMEV air handling unit

## VEX260

### VEX260

VEX200 is an energy-efficient air handling unit with rotary heat exchanger and ALC™ technology, which ensures the best indoor air quality without compromise.

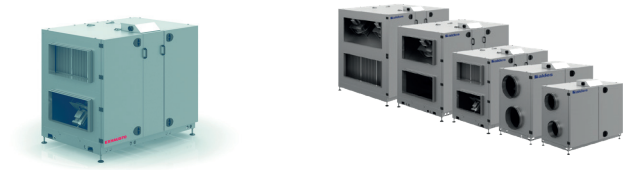

#### PRODUCT BENEFITS

- Available as indoor and outdoor model
- Optimal air quality and thermal comfort
- Very low noise level

#### REGULATIONS AND COMPLIANCES

Eurovent Certification no. : 16.01.020

#### Principles of operation

The VEX 200 brings fresh, filtered air into the building and recovers heat from exhaust air using its high-efficiency heat exchanger. The incoming air can be heated and/or cooled using a comprehensive range of coils.

#### Product description

VEX200 is a range of energy-friendly air handling units with rotary heat exchangers and EC motors. You can choose between two rotor types, standard and high efficiency. Choose ALC™ when you want to ensure a good indoor climate. ALC™ allows you to transfer humidity while eliminating recirculation of particles, aerosols, viruses, etc. The many versions of the VEX200 range permit a high level of flexibility in installation and location as you can choose spigot location in the units end, top and bottom.

The units are delivered with integrated control systems, that are accessed via the connection box on the front of the air handling unit.

VEX200 air handling units are supplied either as a complete air handling units (VEX240-250) or sectional units (VEX260--280).

#### Fields of application

New, Refurbishment, Non-residential buildings, Schools

#### Installation

- equipment rooms / terraces,
- indoors / outdoors,
- in-line duct connection or choice of two vertical fixings,
- connection via circular or rectangular fixings, depending on model,
- choice of left or right side for equipment fittings.

## CMEV air handling unit

### VEX260

#### VEX260

##### Main characteristics

- The ALC™ (Automatic Leakage Control) option is the patented solution that prevents the propagation of viruses by air handling units equipped with rotary heat exchangers. It measures, checks and constantly adjusts the pressure difference between supply and return airflows to ensure that no stale air comes into contact with the clean air produced by the unit.
- Monoblock or multi-block units depending on the model.
- Self-supporting construction with dual-wall panels.
- External finish in Aluzinc AZ185: class 4 anti-corrosion performance.
- 49 mm mineral wool insulation (class A1 as per DIN4102), 65 kg/m<sup>3</sup> density.
- EN 1886 values: D2, L2/L2, T2, TB3, F8, F9
- Configurable connections.
- EC motor and Exstream high-performance backward curve impeller,
- Easy to access and maintain: components mounted on slides, adjustment accessible via a specific central hatch.
- 2 choices of efficiency on rotary exchanger (Eurovent AARE) with optional drain zone to preserve indoor air quality.
- 4 choices of exchanger types on request:
  - standard aluminium exchanger,
  - hygroscopic,
    - sorption: ideal for hot and humid climates,
    - epoxy: ideal for corrosive atmospheres (saline).
- Choice of filters to guarantee air quality: flat filters or M5 bag filters (ePM10 50%) and F7 (ePM1 65%) - consult us for other types of filters and pre-filters.
- Built-in switch
- EXact2 controller:
  - constant speed,
  - multi-speed,
- constant pressure,
  - 0-10 V.
- Configuration & monitoring via:
  - wired remote control,
  - option: Webserver and BMS communication via Modbus RTU / RS485, BACnet MSTP / BACnet IP protocols,
  - option: Webserver and BMS communication via a gateway supplied to Modbus TCP-IP or LON protocols.

#### CMEV air handling unit

## VEX260

### VEX260

#### Supplementary characteristics

- Flexible connection to duct system with automatic leakage control (ALC™):
  - Horizontal, top and bottom
- Compact design for small rooms – available as a unit or optionally as a SPLIT unit

#### Accessories

Description	Variants
VEX260, add on for OD	V260OD
Closing damper, 400x800	LS400X80024
Closing damper, 400x800, OD	LS400X80024OD
Closing damper with spring-return 400x800	LSR400X80024
Closing damper with spring-return 400 x 800 mm, OD	LSR400X80024OD
ALC damper, 400x800	LS400X800ME
ALC damper, 400x800, OD	LS400X800MEOD
ALC damper, 400x800; Modbus	LS400X800MED
ALC damper, 400x800, Modbus, OD	LS400X800MEDOD
Modbus communications module for analogue and digital inputs and outputs	MIO
Manual override timer button	TIMERBUTTON
Manual override to comfort mode excl. MIO - incl. cable	TIMERBUTTON2
Motion sensor for override at comfort level (MIO)	PIRB-AS
Motion sensor for override at comfort level (Modbus)	MIOPIR2
HW050X08002U0UL	MIOTSRROOM
Temperature sensor for duct incl. modbus communications module	MIOTSDUCT
CO2 sensor – room (MIO)	MIOCO2ROOM
CO2 sensor duct (MIO)	MIOCO2DUCT
RH sensor, room (MIO RH-ROOM)	MIORHROOM
Touch panel 3.5	MHI2-350-TOUCH
Pressure sensor for constant pressure regulation	MPTDUCT
Motion sensor - digital - excl. MIO	PIR2
CO2 room sensor analogue 0–10 V (can be reprogrammed)	CO2ROOM
CO2 room sensor analogue 0–10 V	RCO2
HW050X08002U0UL	RCO21000
CO2 duct sensor analogue 0–10 V (reprogrammable)	CO2DUCT
CO2 duct sensor analogue 0–10 V	KCO2
HW050X08002U0UL	KCO21000
Air quality sensor - excl. MIO	RLQ
RH sensor for room - analogue 0-10 V (0-100 % RH)	RFF

#### Filters

Description	Variants
Bag filter for VEX260 – ePM10 60%	FB260M5
Bag filter for VEX260 – ePM1 60%	FB260F7
Panel filter for VEX260 – Coarse 85%	FP260M5
Panel filter for VEX260 – ePM1 55%	FP260F7
Panel filter for VEX260, combi - Coarse 60%	FPC260G4
Panel filter for VEX260, combi - ePM10 80%	FPC260M5
Panel filter for VEX260, combi - ePM1 50%	FPC260F7
Panel filter for VEX260, combi– ePM1 80%	FPC260F9

#### Associated services

Commissioning

#### Rotor drive - stepper motor

Rotary stepper motor - Voltage (V)	230
Rotary stepper motor - Phase current (A)	0,2
Rotary stepper motor - Power consumption (W)	45
Rotary stepper motor - Over-current protection	Eingebaut
Rotordrev stepmotor, Control (built in rotation monitor)	Continuously variable from 0 to 10 rpm on the rotor

## CMEV air handling unit

**VEX260****VEX260****General data**

Motor class in accordance with IEC TS 60034-30-2	IE5 (Ultra Premium Efficiency)
Voltage input	1 x 230
Regulation	Variable via motor control (MC)
Control signal with control system	Modbus
Control signal with third party control system	0-10 V DC
Fluid temperature (air)	-40°C....+40°C
Ambient temperature range	-30°C....+50°C

**Fan data**

Max. Total efficiency (A-D) (%)	57,1
Efficiency level requirements	62N (2015)
ECO efficiency level during optimal operating point	67,2N
EC motor	Med motorcontroller (VSD)
Overload protection	Built-in

**Dimensional data**

A (mm)	1820
A1 (mm)	710
A2 (mm)	400
B (mm)	1370
C (mm)	1265
Connection, horizontal measurement (mm)	800
Connection, vertical measurement (mm)	400
Weight (kg)	525
Weight for transport	Fan sections: 2 x 117 kg Rotor Section: 127,5 kg

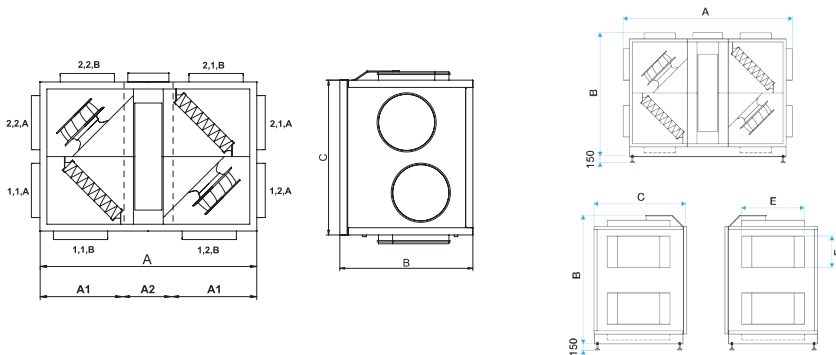
**Airflow data**

Minimum airflow	1200
Max. airflow ErP (m³/h)	4370
Airflow (m³/h)	4551
Max. airflow (m³/h)	5540

**Heat recovery data**

Max. exchanger output (%)	90
Max. current absorbed (kW)	18

**Electrical datas**

Voltage (V)	3x400
Frequency (Hz)	50
Max. power of electrical coil 1 (kW)	14
Max. current consumption THREE-PHASE 400 V (A)	18
Maximum current - unit (A)	18
Max current of zero (A)	23,5
Max. electrical output of unit (kW)	5,0
Power consumption (kW)	2,359

CMEV air handling unit

**VEX260**  
**VEX260**

**Regulatory data**

Strength of unit housing	D2
Tightness at negative pressure of -400 Pa	L1
Tightness at positive pressure of +700 Pa	L1
Filter bypass Leakage	F9
Thermal transmittance	T2
Thermal bridging factor	TB3

**Installation**

The easily accessible connection box with built-in switch disconnecter and control system fuses ensures easy access for connecting and service.



**MECHANICAL PERFORMANCE:**

According to DS/EN 1886 and certified by Eurovent:

- > Casing strength: D1 (M)
- > Airtightness under negative pressure at -400 Pa: L1 (M)
- > Airtightness under positive pressure at +700 Pa: L1 (M)
- > Filter bypass leakage: F9 under negative and positive pressure
- > Thermal transmittance: T2 (M)
- > Thermal bridging factor: TB3



**EXstream performance:**

The units are equipped with EXHAUSTO EXstream impellers, one of the leading air fan impellers on the market in terms of low energy consumption and low sound level.

The fan impeller rpm and the number of vanes have been optimised so that the "vane frequency" is in the 500 Hz band. This means that fewer/smaller silencers are required than normal and it costs less to sound proof at frequencies of 500 Hz than it does with frequencies of 125/250 Hz (the typical range).



The cabinets are made from Aluzink AZ185 class C4 and insulated with 50 mm mineral wool. This results in low noise emissions to the external environment/ installation location.

The panel construction minimizes the formation of thermal bridges in the air handling unit.



The motor sections are mounted in vibration dampers, which reduces noise in the ducts and eliminates the need to fit flexible connections between the unit and the duct system.

The motor sections can be pulled out for easier servicing.

The motors are of type EC and are extremely efficient. They comply with the requirements of the Ecodesign Directive.

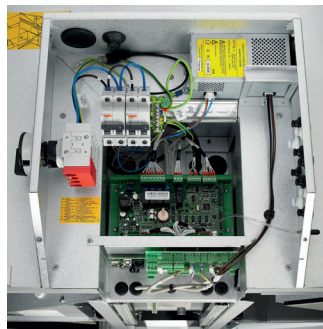

The easily accessible connection box with built-in switch disconnecter and control system fuses ensures easy access for connecting and service.



The mounting base has feet with an adjustable height.

The base is an accessory for VEX240/250, but standard on the other models, where the unit is assembled at the bottom by using the base, and via trunk fasteners at the top.

## CMEV air handling unit

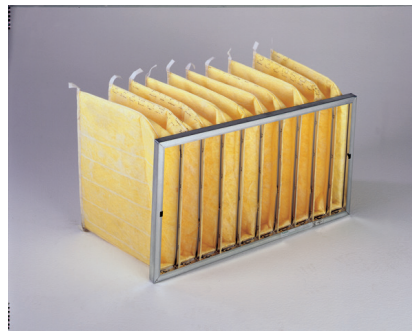
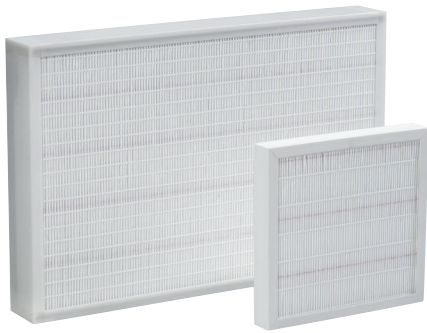
**VEX260****VEX260**

VEX200 series can be supplied with panel filters and bag filters.

Filter class in acc. with EN779:

Panel filters: Coarse 85% (M5) or ePM1 55% (F7)

Bag filters: ePM10 60% (M5) or bag filters ePM1 60% (F7).

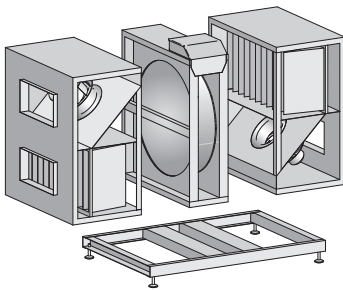

With some projects, limited space means that internal transport of the air handling unit is difficult or impossible. This is why the VEX200 is available as a split version. It means that the air handling unit can be assembled and tested at the factory as normal – just without sealant. The air handling unit can therefore be easily taken apart at the installation site, transported as single sections, assembled, sealed and commissioned.



> EXact2 control system:

- Constant speed
- Several speeds
- Constant pressure
- 0–10 V

> Configuration and monitoring via:

- Wired remote control
- Option: Web server and BMS communication via Modbus RTU/RS485, BACnet MSTP/BACnet IP protocols
- Option: Web server and BMS communication via a bridge for Modbus TCP/IP or LON protocols

CMEV air handling unit

**VEX260**  
VEX260

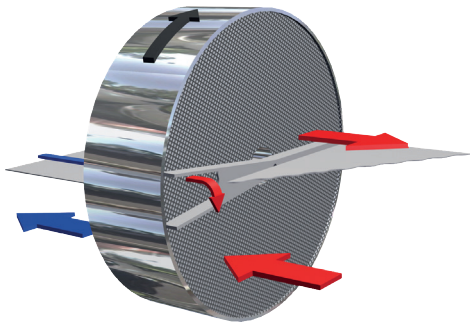

The aluminium rotary heat exchanger with low pressure drop and a temperature efficiency of 80%. The rotor control comprises a step motor with motor control.  
Efficiency:  
> Rotor with wave height of 1.4 mm - very high efficiency  
> Rotor with wave height of 1.8 mm - very high efficiency



The combination of modern EC motors and the EXHAUSTO motor controller delivers extremely low energy consumption and with the EXstream impeller, a high output is achieved.

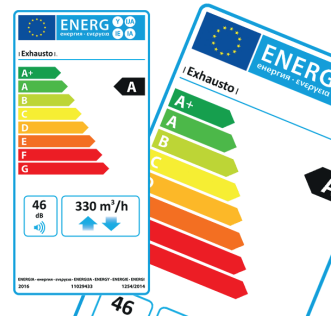

An energy label that states the energy class of the air handling unit in relation to defined operating conditions is available via our product calculation programs.

**Principles of operation**

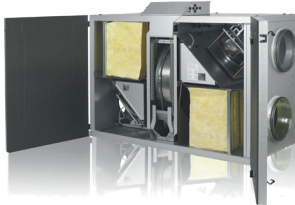

VEX200 is a range energy-friendly air handling units with rotary heat exchangers and EC motors. You can choose between two rotor types, standard and high efficiency.

The many versions of the VEX200 range permit a high level of flexibility in installation and location as you can choose spigot location in the units end, top and bottom. Read more under Variations.  
The units are delivered with integrated control systems, that are accessed is the connection box on the front of the unit.  
VEX200 units are delivered either as a complete unit (VEX240-250) or split into sections (VEX260-280).

VEX500 operation

**Curve**

